



Horizontal Chest Press Plate Loaded ASSEMBLY INSTRUCTIONS



Please take the time to carefully read the instruction manual before starting the process of assembling your machine. If you have any inquiries or complications, please call us at 662-GYM-BROS, or email us at info@gymbrofitness.com.

Ensure to tighten all nuts and bolts, lubricate any sliding parts, bearings, and moving mechanisms. We also suggest applying Loctite or any kind of thread locking adhesive to anything that does not thread into a Teflon nut. It is also important to ensure that every movement arm is properly aligned prior to frequent use, and that the machine that you are assembling is fully functional.

Tools Required for Installation:
Rubber Mallet
Level
Ratchet and Socket Set
Snap Ring Pliers
Adjustable Wrench
2 People Required

PARTS/HARDWARE LIST

Part Number	Part Description	Quantity
A1	Main Frame	1
A2	Connection Frame (1)	1 pair
A3	Connection Frame (2)	1
A4	Side Frame	1 pair
A5	Arm Support Frame	1
A6	Arm	1 pair
1	Footpads	5
2	Hexagon Socket Flat Head Screws M12x70	14
3	Flat Pad (1)	14
4	Flat Pad (2)	22
5	Self Locking Nut M12	16
6	Hexagon Socket Flat Head Screws M12x120	2
7	Hexagon Socket Head Screws M12x30	2
8	Square End Cap	4
9	Sleeve Pad	4
10	Sleeve End Cap	4
11	Sleeve Tube	4
12	Sleeve End Cap	6
13	Hexagon Socket Head Screws M120x15	10
14	Deep Groove Ball Bearings	4

PARTS/HARDWARE LIST Continued

Part Number	Part Description	Quantity
15	Handle Limit Rings	2
16	Handle Cover	2
17	Handle End Cap	2
18	Flat Pad	4
19	Arm Axis	2
20	Hexagon Socket Head Screws M10x35	4
21	Dampening Piece	2
22	Hexagon Socket Head Screws M12x20	2
23	Sleeve End Cap	2
24	Sleeve Rod	2
25	Sleeve tube	2
26	Back Pad Group (1)	1
27	Back Pad Group (2)	1
28	Hexagon Socket Head Screws M8x30	6
29	Flat Pad	4

Frame Assembly

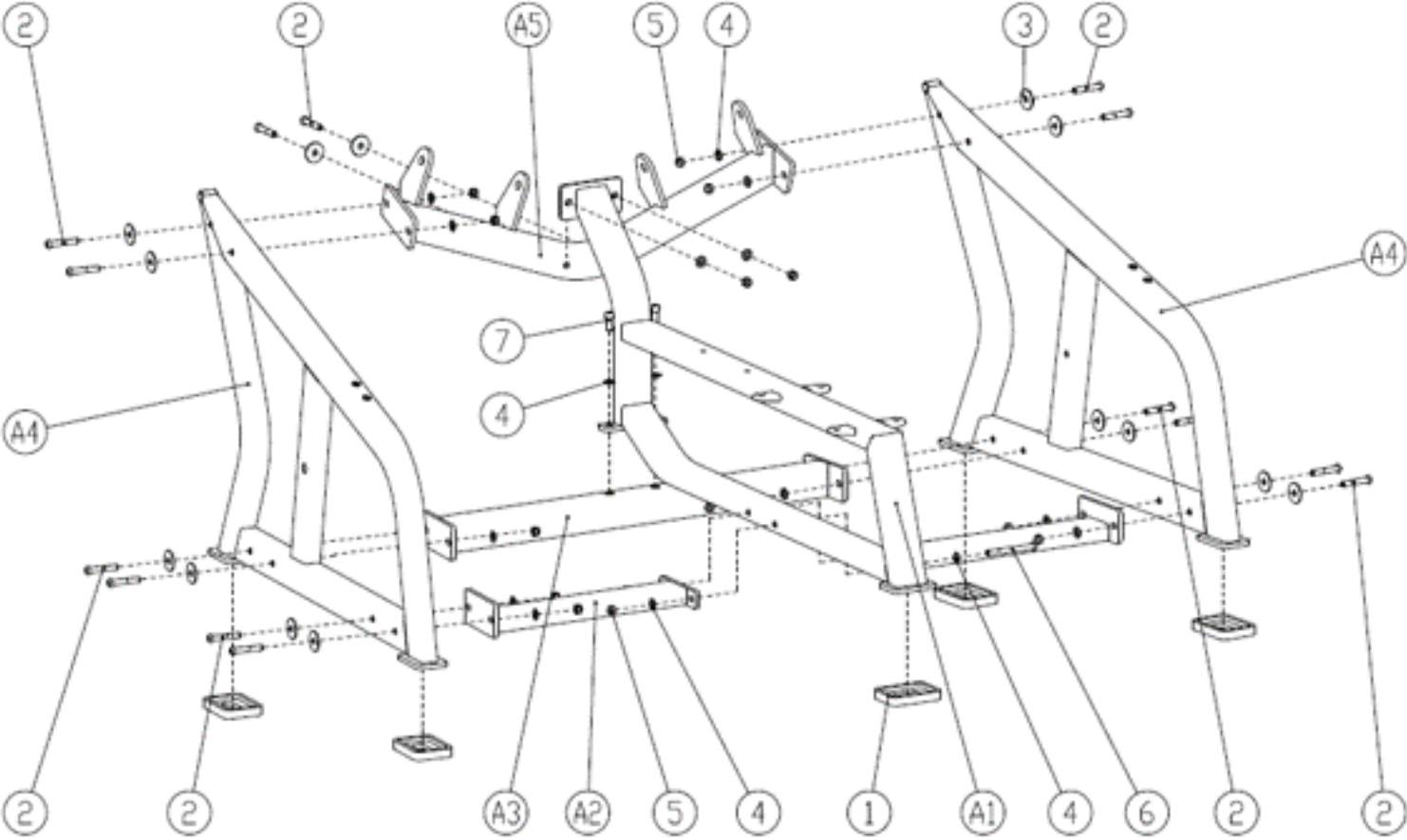

Force Arm Assembly

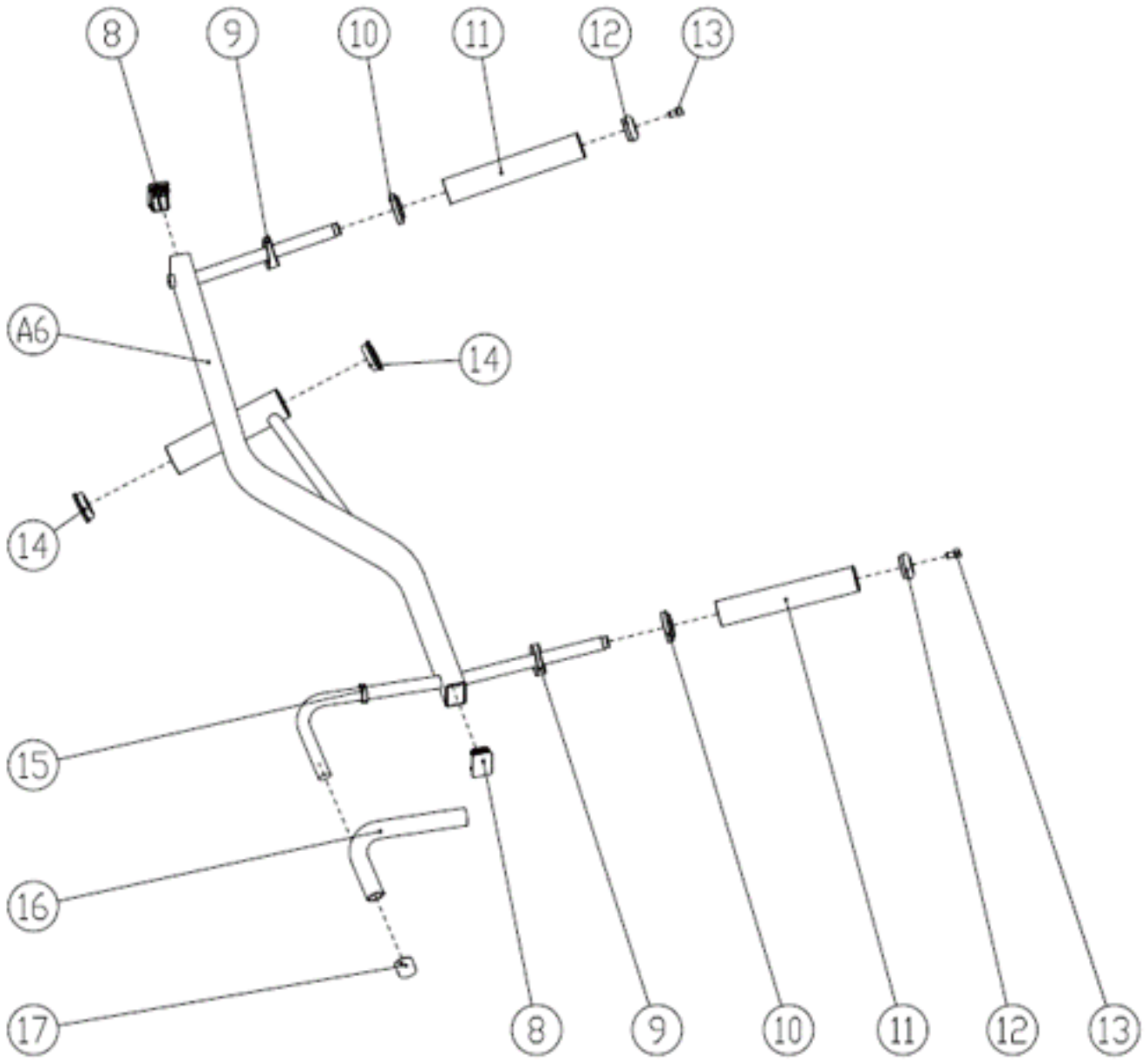

Force Arm Installation

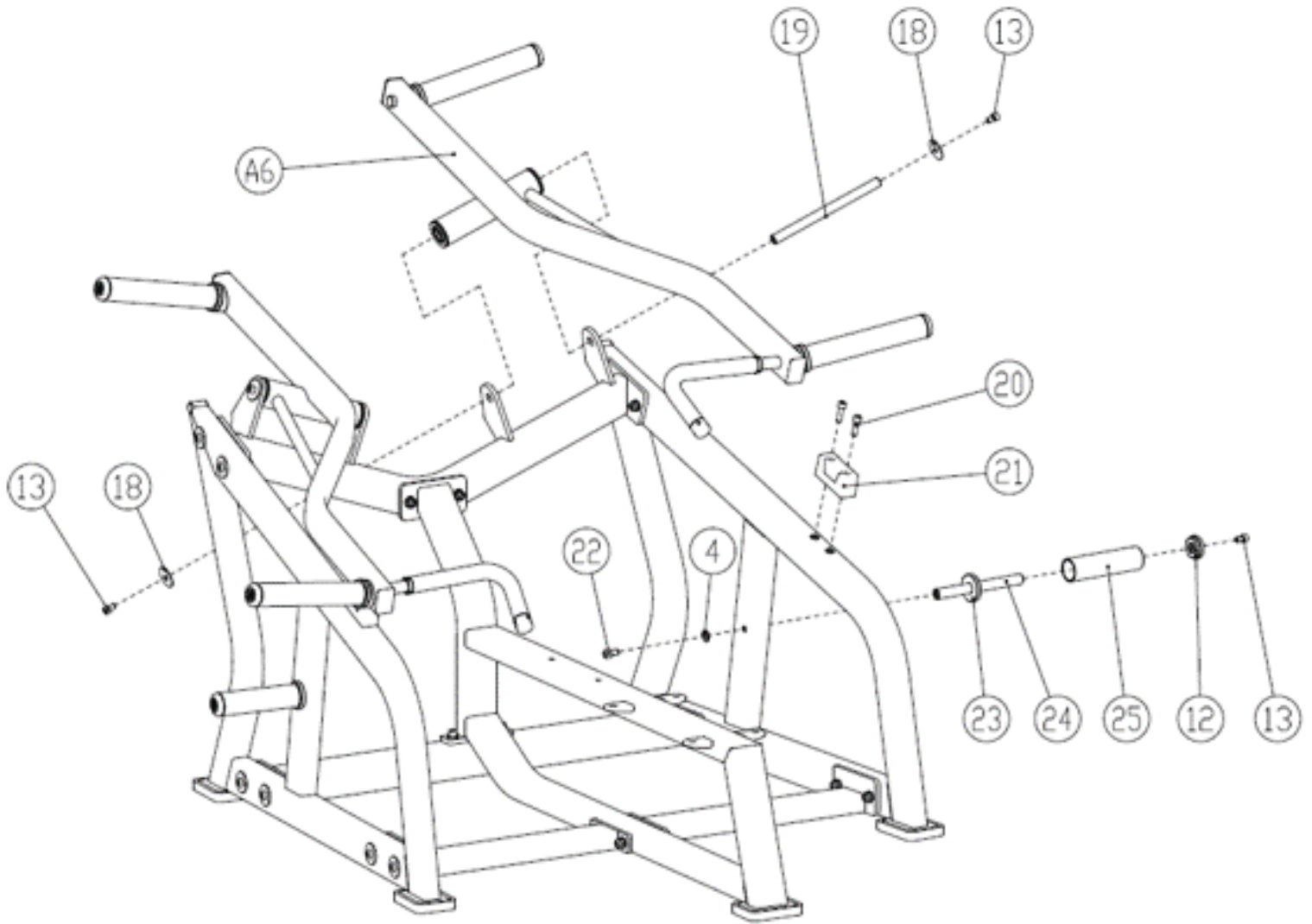

Cushion Installation

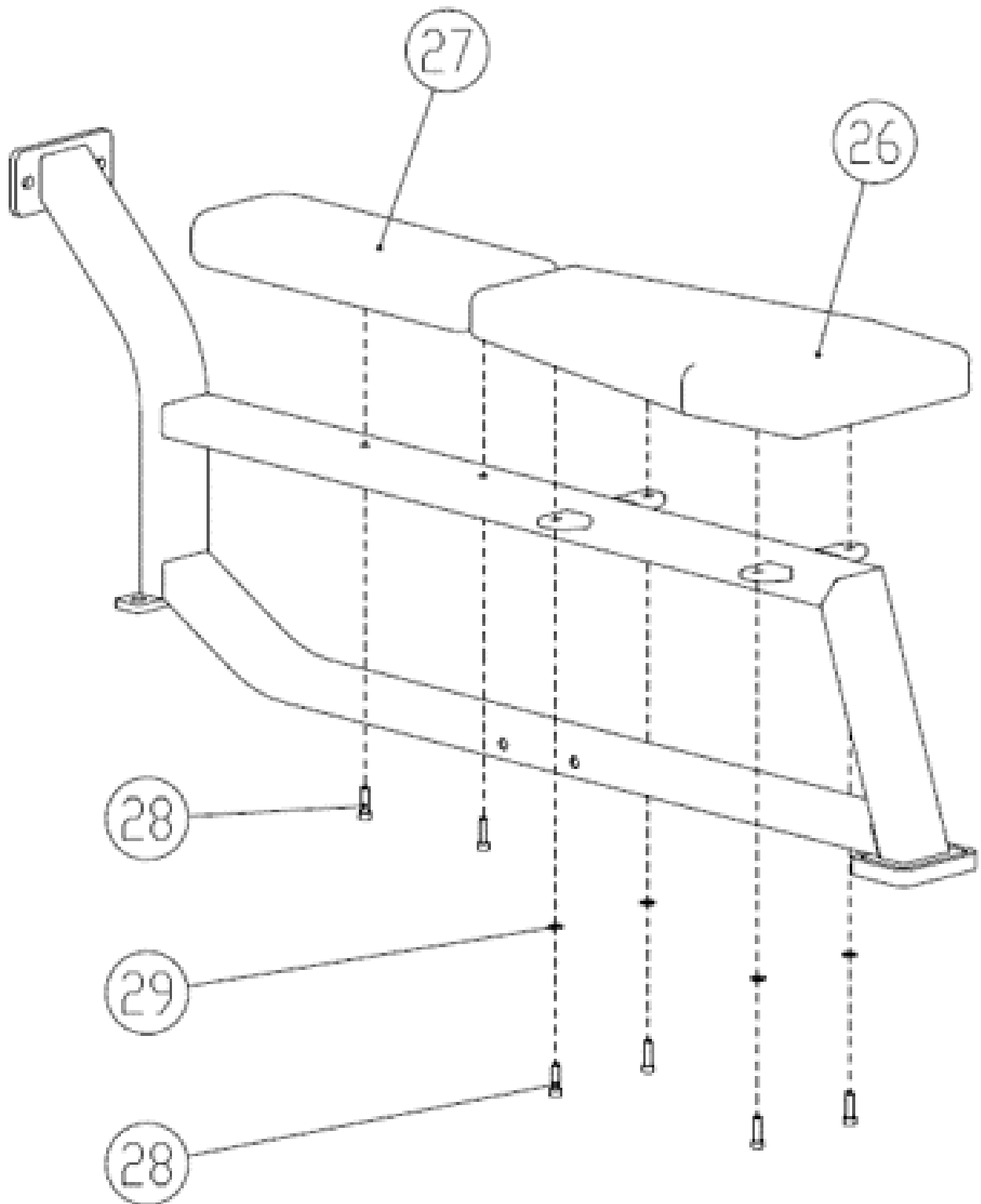

Final Product

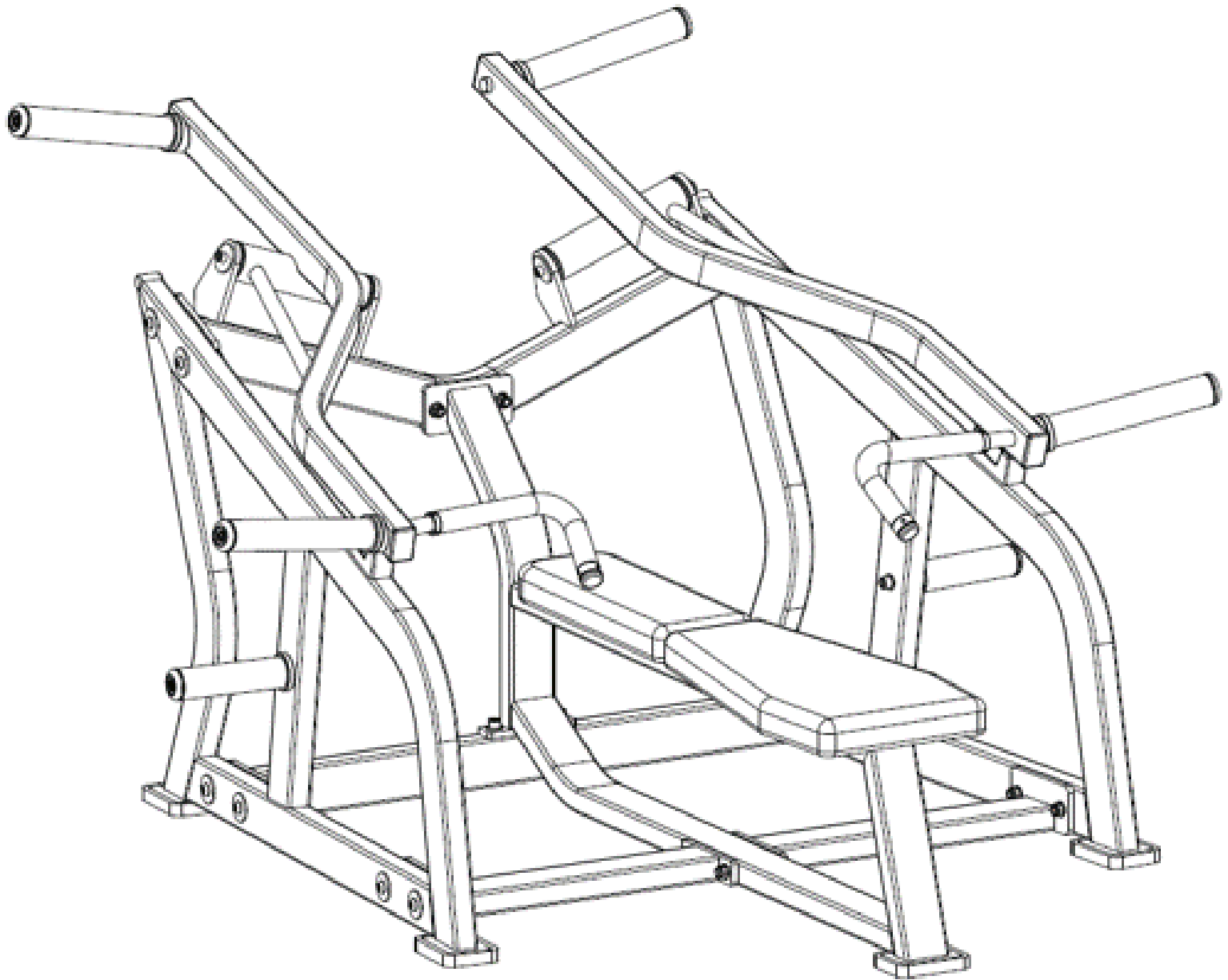

Have a question about assembly?



Please contact a Gym Bro Fitness Team Member!

Hours of Operation:

Monday-Friday 9:00am - 5:00pm (PST)

Saturday 9:00am - 3:00pm (PST)

Sunday CLOSED

Phone: (662)GYM-BROS

Email: info@gymbrofitness.com

Visit Our Website: www.gymbrofitness.com